



Pannier Rack Battery Installation Guide

Cyclotricity Electric Bike Conversion Kit

September 2012 2nd edition

Part 1 – Before Installation

Disclaimer

The Cyclotricity eKit is supplied as a set of do-it-yourself parts for the user to install on their bicycle. Because this kit is installed, maintained and operated by the purchaser, Cyclotricity Ltd disclaims any responsibility for injury, damage or any other consequences arising from the use of this product.

Each installation will be different and therefore it is the responsibility of the purchaser to determine the best way to install the kit on their particular bicycle. The provided instructions should be considered as general guidelines only – every electric bike conversion will be slightly different. If you do not have the mechanical ability to correctly and safely install this electric bicycle conversion kit, you should obtain the services of a professional bicycle shop or other qualified technician.

Installation and use of this e-bike conversion kit will create an electric motor vehicle that has exposed moving parts, electrical connections and high powered batteries. Any or all of these components can be dangerous!

Battery care

- 1- The battery is detachable and comes with a key to lock it in place. Please note that the battery lock is only meant to prevent it from falling off during cycling and should not be regarded as a security lock against theft. We recommend you detach the battery and carry it with you whenever you leave the bike in public places as it is the most expensive part in your product to replace.
- 2- Before you use the battery for the first time it is best to give it a full deep charge for 12 hours. To fully condition your new battery give it complete deep charge, discharge cycles for the first three charges. This is achieved by charging your battery for 12 hours and then using the bike until the battery is completely drained.
After this “conditioning” process, you can leave the battery charging as and when you require.
- 3- If you are going to leave your battery uncharged for more than eight weeks it is best left half charged. You should then re charge it every four weeks for two hours to keep it in top condition.
- 4- Always remember that you use up to three times more power when setting off under the thumb throttle. To preserve the life of each charge always set off using pedal assist.
- 5- Check the indicators on the actual battery to see how much power you have left.
Please note that the indicators on the handlebar dashboard (if purchased) lights do not necessarily show the amount of power you have left, but the amount of load the battery is experiencing at any one point. If the lights go down to “Empty”, then this is a strong indication that you ought to be pedaling more to take some of the load off the battery. This will improve the battery life cycle.
- 6- Do not expose the bicycle or battery pack to fire, heat sources, acid or alkaline substances.
- 7- For best results, always charge the battery at room temperature.
- 8- Always make sure the battery is turned off before detaching/connecting it.
- 9- If your battery is damaged or appears to be overheating for any reason immediately return it to your retailer for advice and a safety check.
- 10- Always dry the battery with a clean dry cloth after cycling in the rain.

Charger

- 1- Red light on the charger means the battery is charging. When the red light turns green, the battery is fully charged. Please ignore the green light and carry on charging for 12 hours for the first 3 charges to condition your battery.
- 2- Always connect the charger to the battery before connecting it to the mains.
- 3- Always disconnect the charger from the mains before disconnecting the charger from the battery.
- 4- Do not leave the charger connected to the mains when not in use.

Water

Your eKit is rain and splash resistant and can be used in all weathers. The electrical components of the vehicle, such as motor, battery, and controller, must not be submerged in water.

WARNING: Do not attempt to open the casings of the battery or motor as it could be dangerous and all warranties will become void. If you experience problems, refer to the troubleshooting guide in this manual or ask your local dealer.

Part 2 –Pannier rack Installation Guide

Step 1 – Opening your battery box

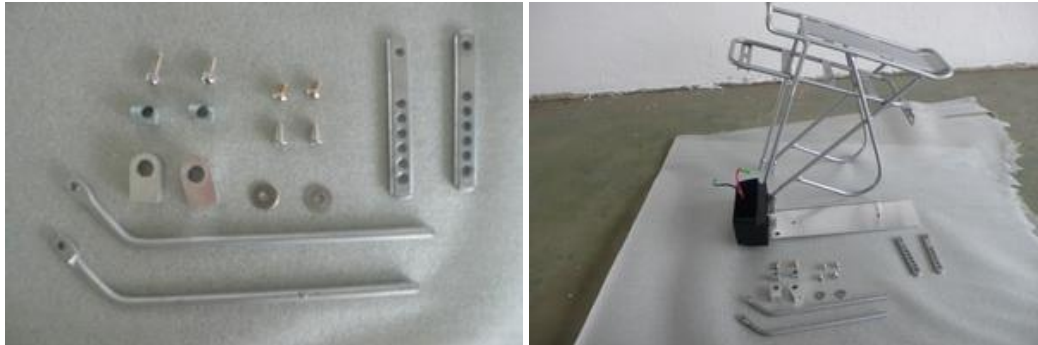

Your pannier rack will come with the fittings shown on the images above. These fittings are sufficient to assemble the pannier rack. However, since each bike is different, the fittings required to mount the pannier on your bike may not be provided (and if provided, may not fit your bike). Please seek assistance from a local bike service shop for the right fittings.

Note: You should find 4 additional screws inside the black plastic box provided with your battery. These screws should be used to affix the plastic box unto the pannier rack only.

Step 2 – Mount the pannier components together as follows:



Step 3 – Assemble the pannier rack as follows:



Step 4 – Mount the pannier rack on your bike:

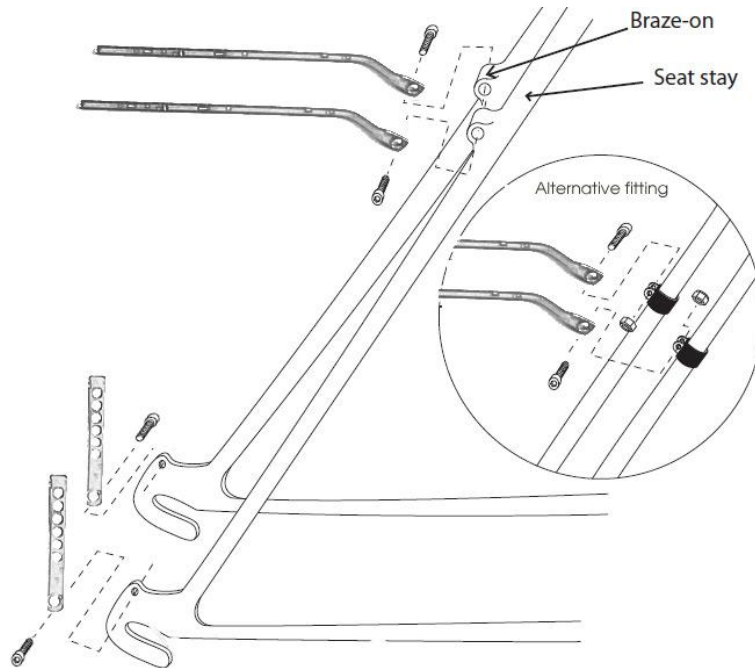

Note: Since each bike is different, the screws (or alternative fittings) shown in this image may not be provided with your battery. Please contact your local bike service shop to source suitable pannier fittings for your bike.

Step 5 – Place the controller into the controller box:



Connect the RED and BLACK battery wires on the controller to the corresponding colours in the controller box. For a full controller connections guide, please refer to your eKit User Manual.

Step 6 – Cover the controller box with the lid provided:

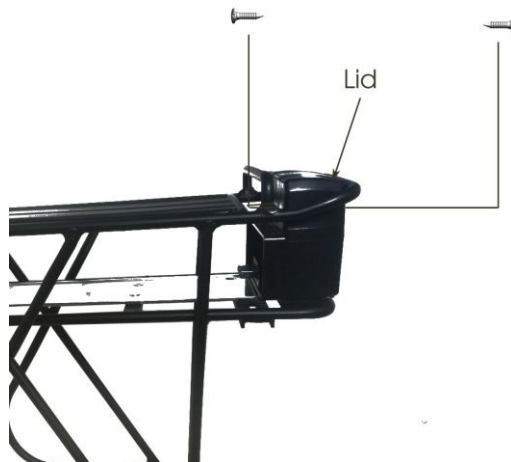

Step 7 – Slide the battery all the way in until it is easily lockable with the key



The battery should slide in and out easily through the rail at the bottom of the pannier rack. In case the battery doesn't slide all the way in and, as a result, you are having difficulties locking the battery in place with the ignition key, this is likely because you have not aligned the controller box on the pannier rack properly. Please perform the following steps to align the controller box:

- Remove the plastic controller box altogether.
- Insert the battery into the pannier (without the controller box being assembled) and lock the battery in place with the key.
- Once this is done, you can then hook the controller box into the battery/pannier and screw it in its position with the 4 controller box screws.
(You may notice that the controller box drilling is slightly out of line with the pannier drilling. Feel free to force the long screws into what remains of the controller box holes and they will expand into line with the pannier rail drilling).